

Differential Pressure Gage for Filter Restriction

20DP, 25DP, A20DP and A25DP Series 2 and 2-1/2 in. (51 and 64 mm) Dial



Features

- Monitors Engine Oil and Fuel Filters
- Actuates Alarm or Shutdown System When Filter Becomes Clogged
- Combination Indicating Gage and Limit Switch
- Actuates Filter Backwash
- Signals Coolant Loss or Aeration On Engine Water Pump

¹ Products covered by this bulletin comply with EMC Council directive 89/336/EEC regarding electromagnetic compatibility except as noted.

The 20DP and A20DP Series (2 inch/51 mm dial) and the 25DP and A25DP Series (2-1/2 inch/64 mm dial) Swichgage instruments are diaphragm-actuated, differential pressure-indicating gages, with a built-in electrical switch. This switch is used for tripping alarms and/or shutting down equipment. These gages are intended to monitor and indicate oil, fuel or water filter restriction and can reduce the risk of dangerously high pressure which may rupture the filter, resulting in contaminants entering the system.

The **20DP and 25DP series** mechanism is enclosed in a steel case coated to resist corrosion. The **A20DP and A25DP series** have a polycarbonate case and are sealed from the environment. All feature a polycarbonate, break-resistant lens and a polished, stainless steel bezel to help protect these rugged, built-to-last instruments.

The gage pointer acts as a pressure indicator and as one switch pole which completes a circuit when it touches the adjustable limit contact. Contacts have self-cleaning motion to ensure electrical continuity.

Features

- **CONSTANT VISUAL INDICATION** of the condition of your filter is shown on the dial.
- **TWO INSTRUMENTS IN ONE** – an accurate indicating gage and adjustable p.s.i.d. limit switch. Reduces inventory and installation time.
- **ADJUSTABLE CONTACT** lets you set the monitoring range of the gage. The contact is tamperproof and can be set only with a 1/16 Allen-head wrench.
- **DURABILITY** – All gages are made of durable materials allowing them to withstand rugged applications.
- **EARLY FILTER CHANGES** cost you money and increase the risk of contaminants entering the system. A Murphy filter restriction Swichgage instrument will let you know when to change the filter and maintain peak efficiency.

Specifications

Dial: White on black, dual scale; U.S.A. standard scale is psi/kPa. Other scales available—inquire.

Case: 20DP and 25DP Series: plated steel. A20DP and A25DP Series: polycarbonate.

Bezel: Polished stainless steel, standard; others are available (see How to Order).

Lens: Polycarbonate, high-impact.

Temperature Range:

Ambient: -40°F (-40°C) thru 150°F (66°C).
Process: -40°F (-40°C) thru 250°F (121°C).

Process Connection: 1/8-27 NPTM brass.

Sensing Element: Beryllium copper diaphragm.

Gage Accuracy: ±3% maximum across scale.

Snap-Switch Rating (“DPE” models): SPDT, 3 A @ 30 VDC inductive; 4 A @ 125 VAC inductive.

Base Models

20DP, 25DP, A20DP and A25DP Swichgage instrument

The gage pointer makes with an adjustable contact to complete a pilot-duty circuit.

20DPE, 25DPE, A20DPE and A25DPE Swichgage instrument

20DPE (was 20DPEO), 25DPE (was 25DPEO), A20DPE (was A20DPEO) and A25DPE (was A25DPEO).

Adjustable Limit Contact: SPST contact; pilot-duty only, 2 A @ 30 VAC/DC; closed when the low limit is met, open when pointer is in normal operating range. Contacts are gold flashed silver.

Limit Contact Adjustment: by 1/16 in. hex wrench thru 100% of scale.

Limit Contact Wire Leads (20DP and 25DP Series): 18 AWG (1.0 mm²) x 12 in. (305 mm).

Limit Contact Terminals: A20DP Series number #4 screw terminals. A25DP Series number 6 terminals.

Unit Weight: 20DP and A20DP Series: 9 oz. (0.25 kg); 25DP and A25DP Series: 11 oz. (0.29 kg).

Unit Dimensions: 20DP and A20DP Series: 3 x 2-3/4 x 2-3/4 in. (76 x 70 x 70 mm). 25DP and A25DP Series: 4-3/4 x 4-3/4 x 2-3/4 in. (121 x 121 x 70 mm).

Features an internal snap-acting SPDT switch, instead of the single pole/pointer contacts. When the switch closes on rising pressure, it becomes set, as pressure falls the switch resets. 20DPG, 25DPG, A20DPG and A25DPG Murphygage instrument gage without contact(s).

Operating Characteristics

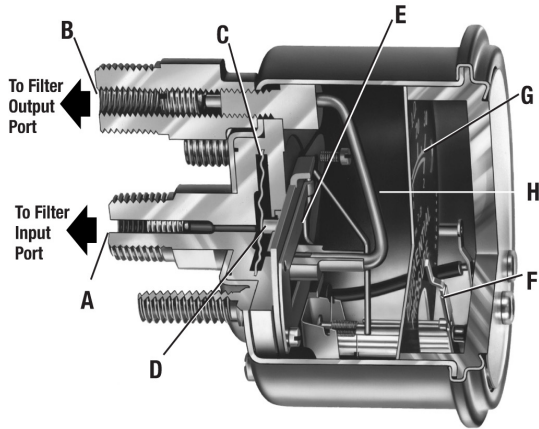

Port **A** connects to the input side of the filter. Pressure pushes diaphragm **C** forward thus pushing the button **D** which turns the crank arm **E** which in turn moves pointer **F** to register the amount of pressure on dial **G**. Port **B** connects to the outlet side of the filter. Pressure is exerted through tube **H** and pushes on the diaphragm thus applying pressure on both sides of the diaphragm. The pointer displays pressure in the amount that the input pressure is greater than the outlet pressure. As the filter is restricted by contaminant's and the pressure difference reaches the critical point, the pointer touches the pre-set limit contact and shuts down the system or activates a visual or audible signal to alert the operator.

Dimensions

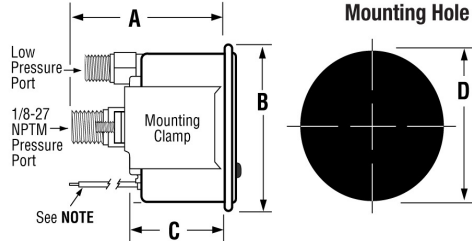

	20DP Series	A20DP Series	25DP Series	A25DP Series
A	2-7/32 (56)	2-9/64 (54)	2-1/8 (54)	1-51/64 (46)
B	2-15/64 (57)	2-1/4 (57)	3-1/8 (79)	2-29/32 (74)
C	1-5/16 (33)	1-27/64 (36)	1-3/8 (35)	1-27/64 (36)
D	2-1/16 (53)	2-1/16 (53)	2-11/16 (68)	2-11/16 (68)

NOTE: 20 and 25 Series have 18 AWG (1.0 mm²) wire. A20 Series has #4 screw terminals and A25 Series has #6 terminals. Dimensions are in inches and (millimeters).

Ranges and Factory Settings

Ranges* Available	Max. Static Pressure	Max. Differential Pressure	Contact Setting
0-15 (0-103) [0-1.0]	50 (345) [3.4]	30 (207) [2.0]	10 (69) [0.8]
0-30 (0-207) [0-2.0]	150 (1.0) [10]	60 (414) [4.0]	20 (138) [1.0]
0-50 (0-345) [0-3.5]	300 (2.1) [20]	100 (690) [7.0]	30 (207) [2.0]
0-75 (0-517) [0-5.0]	300 (2.1) [20]	150 (1.0) [10]	50 (345) [3.5]
0-100 (0-690) [0-7.0]	300 (2.1) [20]	200 (1.4) [14]	60 (414) [4.0]

* Values are shown in psi, (kPa/MPa) and [bar]. Values in kPa/MPa and bar are mathematical conversions from psi—they do not reflect actual second scale range.

Internal Wiring

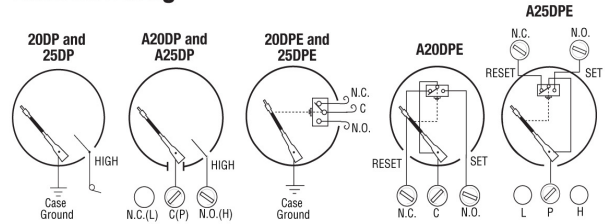

How to Order

To order, use the diagram below. List options in ascending alphabetical order (A-Z). Example: **20DP-F-30**.

Base Model	Range ^{††}
20DP	15 = 0-15
A20DP	30 = 0-30
20DPE	50 = 0-50
A20DPE	75 = 0-75
20DPG	100 = 0-100
A20DPG	

^{††}Select scale so your normal operating pressure is in the middle half of the scale.

Options[†]

A = Argon filled case (not available for A25DP, 25DPE, 20DPE Series)
B1 = Black bezel
B2 = Bezel 05051857 (was "HP")
B3 = Bezel 05051836 (was "HBB")
EX = Explosion-proof
EL = Explosion-proof less case

F = "FS" contact (includes "ES" as appropriate)
K = Knob adjusting face contact

[†]Options not available on all models or configurations.