

# Shutdown Panel Kits for Deutz and Other Engines

DTZ-94100B  
Revised 04-06  
Catalog Section 30  
(00-02-0082)



## W0156 and W0169

- Protection Against Dangerously Low Oil Pressure or High Temperature
- Closed-loop Circuitry Ensures Proper Operation at All Times
- Weatherproof and Shock-Mounted
- Complete Kit Ready for Easy Installation
- Fits Deutz FL912 and FL913 Series and Other Engines

### Description

The W0156 and W0169 panel kits were developed specifically for air-cooled and liquid-cooled engines where a weather proof engine panel is required. Both kits features Swichgag<sup>®</sup> protection for low engine oil pressure and high cylinder head or high oil temperature. Shock-mounted panel bolts directly to the flywheel housing or bracket of your design.

These kits were originally designed for Deutz FL912 and FL913 series engines, but can be used on a variety of engines. Internal wiring mates with standard Deutz circuit.

### Panel kits include:

- Low Lube Oil Pressure Swichgag instrument
- Cylinder Head/Oil Temperature Swichgag instrument
- 518PH Magnetic Switch.
- Alternator failure light.
- Ignition key switch.
- Provisions for additional Swichgag instruments such as irrigation pump pressure or voltmeter/ammeter etc.
- Provisions for tachometer.

Swichgag products are two instruments in one: (1) an accurate indicating gage with (2) a built-in, adjustable limit switch.

A 518PH Magnetic Switch provides a Closed-loop circuit to ensure proper operation at all times. The 518PH allows the system to be sensitive to open circuits, broken wires, false grounds, corrosion, loss of power and other factors which could otherwise prevent the protective controls from operating. It can be wired to either make or break a circuit for shutdown.

The mounting panel is enclosed. Panel Kits are prewired and ready to install and are available for 12 or 24 VDC systems\*.

### Specifications

#### Low Lube Pressure Swichgag:

- 0-100 psi (0-689 kPa) [0-6.89 bar].
- 1/8 NPT process connection.

#### Temperature Swichgag:

- Cylinder Head Temperature (W0156): 160-320°F (71-160°C), M10 x 1.5 process connection.
- Oil Temperature (W0169): 130-250°F (54-121°C), 1/2NPT process connection (see Murphy General Catalog for optional sizes).
- 48 in. (1.2 m) capillary.

### 518PH Magnetic Switch:

12 or 24 volt (specify).

**Shipping Weight:** 14lb. (6.4 kgs.).

### Shipping Dimensions:

14-7/8 x 14-7/8 x 6-3/4 in. (378 x 378 x 171 mm).

### How to Order

Specify part number.

**W0156:** For air-cooled engines.

**W0169:** For liquid-cooled engines.

\*NOTE: 12 volt kit is standard. If you require 24 volt kit-specify when ordering.

### Warranty

A limited warranty on materials and workmanship is given with this FW Murphy product. A copy of the warranty may be viewed or printed by going to [www.fwmurphy.com/support/warranty.htm](http://www.fwmurphy.com/support/warranty.htm)

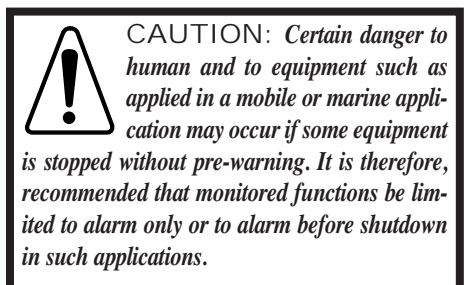

# Dimensions

Dimensions are for both Panel Kits.

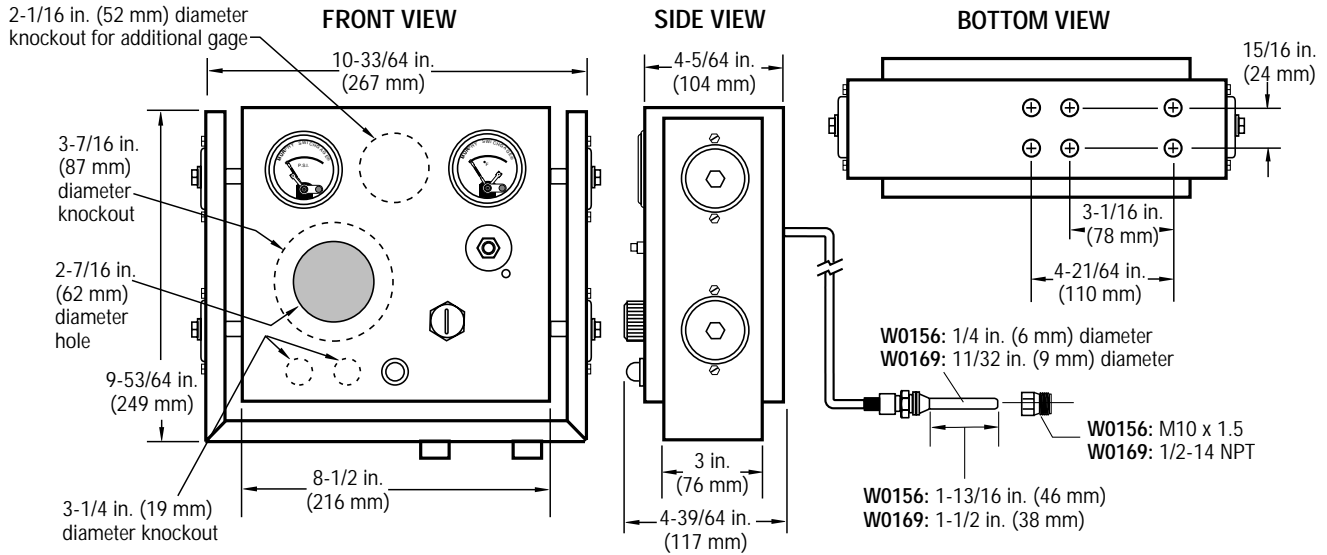

## Typical Wiring Diagram for Deutz

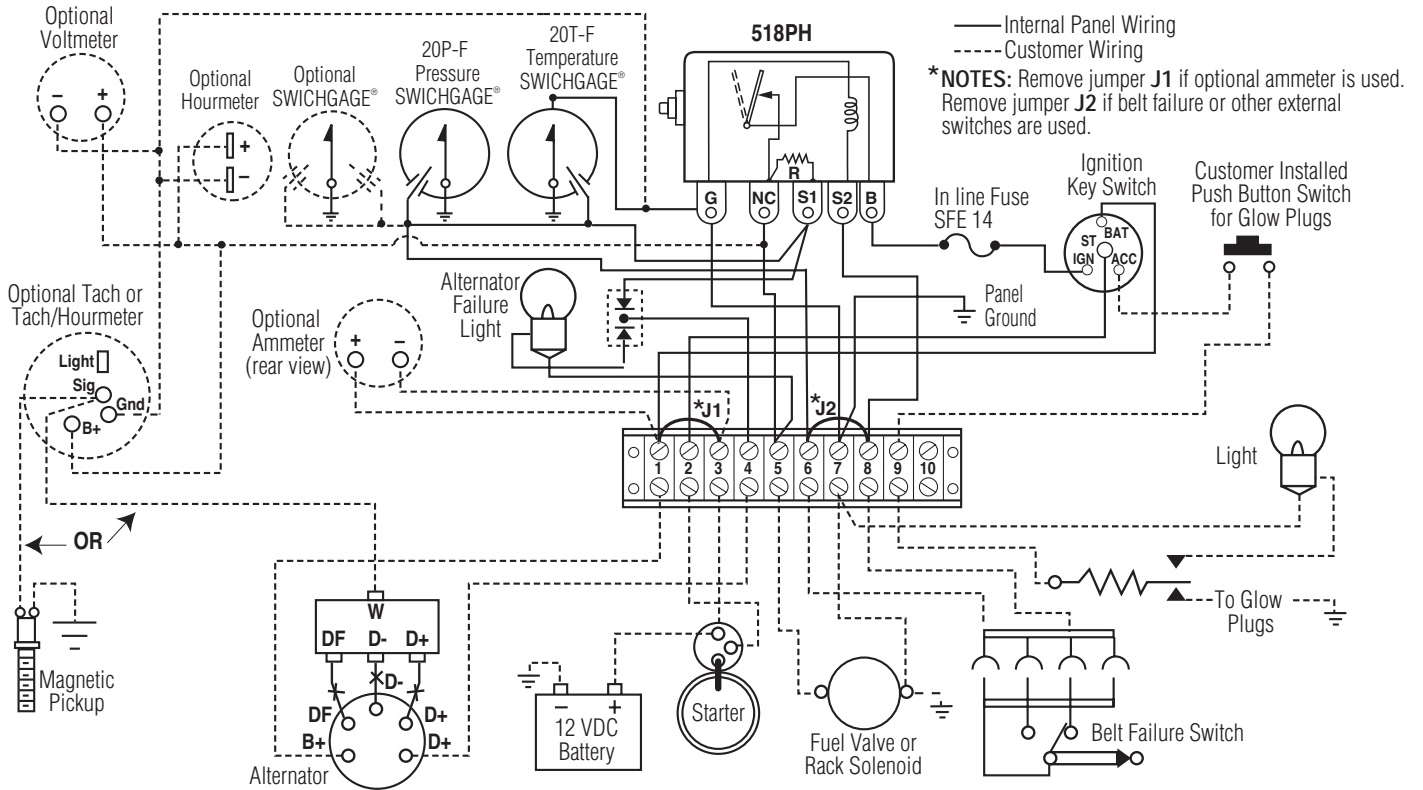

**MURPHY**

www.fwmurphy.com

918.317.4100 Email: sales@fwmurphy.com

In order to consistently bring you the highest quality, full featured products, we reserve the right to change our specifications and designs at any time. MURPHY, the Murphy logo are registered and/or common law trademarks of Murphy Industries, Inc. This document, including textual matter and illustrations, is copyright protected by Murphy Industries, Inc., with all rights reserved. (c) 2006 Murphy Industries, Inc.

In order to consistently bring you the highest quality, full featured products, we reserve the right to change our specifications and designs at any time.