

Standard Vent Clutches

Grinding Mill Clutches

- Designed for heavy duty applications
- Quick, smooth starting
- High heat dissipation for jogging and inching

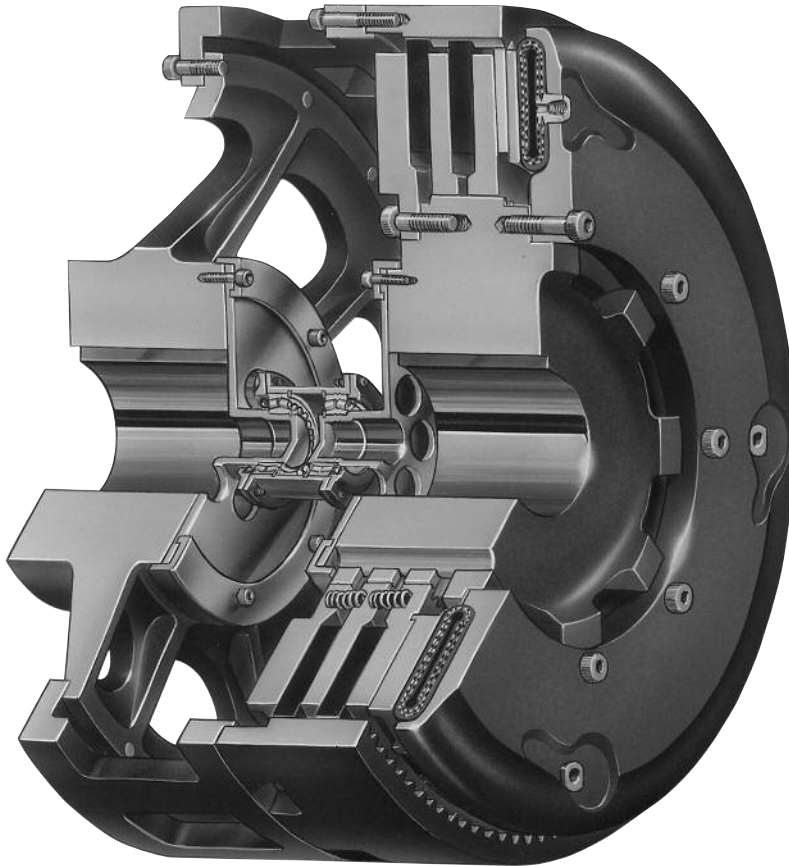

Wichita Grinding Mill Clutches are specially designed to provide quick, smooth starts with limited current surge for heavy duty grinding mills. The clutch is adaptable to remote control allowing centralized operation through simple air or electric circuits.

- No adjustment or lubrication
- Eliminates need for special high torque motors
- Torque capacity not affected by centrifugal force
- High heat dissipation for jogging and inching
- New high coefficient, high energy absorbing friction material standard for grinding mill applications

Standard Torque Motor with Wichita Clutch vs. High Torque Motor

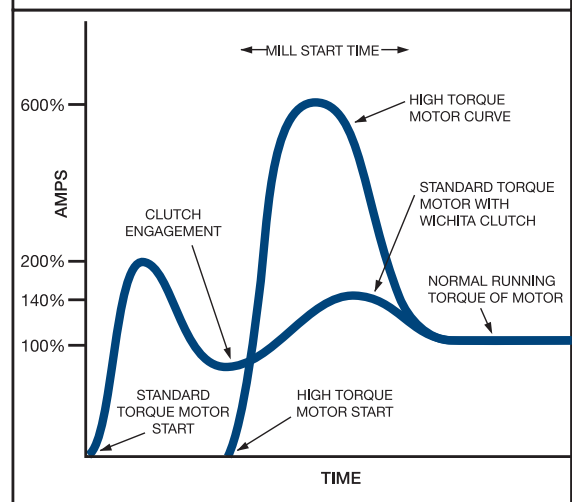

Standard Vent Clutches

Grinding Mill Clutches Specifications

Technical						Capacity				
Model Size ATD-	Air Supply	Total Weight lb.	Total WR ² lb.ft. ²	Driving Adapter Ring & Disc		Diameter Friction Disc-in.	Max. Speed (RPM) For 6000 FPM @ Fric Disc O.D.	HP per 100 RPM	Lining Area in. ²	Rated Torq. in.lbs. 100 PSI
				Wt.	WR ²					
211-X GMC	5/8"-18	130	24	57	16	11	2,100	18	228	42,294
214H-X GMC	5/8"-18	333	111	152	58	14	1,640	40	336	95,228
314H-X GMC	5/8"-18	385	132	190	75	14	1,640	60	504	142,842
318H-X GMC	1"-14	727	333	356	220	18	1,275	120	792	299,250
321-X GMC	1"-14	980	663	500	280	21	1,100	150	1,086	349,790
324H-X GMC	1"-14	1,350	970	590	600	24	950	270	1,722	613,130
327-X GMC	1"-14	1,580	1,130	675	540	27	850	300	2,190	688,275
230H-X GMC	1"-14	2,126	2,046	1,036	1,150	30	760	380	1,664	869,820
330H-X GMC	1"-14	2,600	2,100	1,125	1,250	30	760	570	2,496	1,304,730
430H-X GMC	1"-14	3,578	2,980	1,497	1,148	30	760	760	3,328	1,739,640
336H-X GMC	1"-14	3,550	4,650	1,510	2,215	36	640	885	3,450	2,134,650
342-X GMC	1-1/2"-12	4,815	10,505	2,315	6,130	42	540	1,275	4,212	2,898,070
248-X GMC	1-1/2"-12	6,580	16,275	2,825	9,523	48	475	1,600	4,020	3,730,650
348-X GMC	1-1/2"-12	7,540	18,470	3,274	9,700	48	475	2,400	6,030	5,595,975
448-X GMC	1-1/2"-12					48	475	3,200	8,040	7,461,300
260-X GMC	1-1/2"-12	10,600	37,300	5,750	23,600	60	380	3,470	7,240	7,913,500
360-X GMC	1-1/2"-12	13,390	47,850	5,900	27,550	60	380	5,200	10,850	11,870,250
460-X GMC	1-1/2"-12	16,860	57,705	7,500	33,238	60	380	6,940	14,480	15,827,000
560-X GMC	1-1/2"-12	20,050	78,642	8,300	28,512	60	380	8,675	18,100	19,783,750
372-X GMC	1-1/2"-12					72	300	7,758	14,460	18,573,450
472-X GMC	1-1/2"-12					72	300	10,344	19,280	24,764,600
572-X GMC	1-1/2"-12					72	300	12,930	24,100	30,955,750

Standard Vent Clutches

Grinding Mill Quick Selection Chart

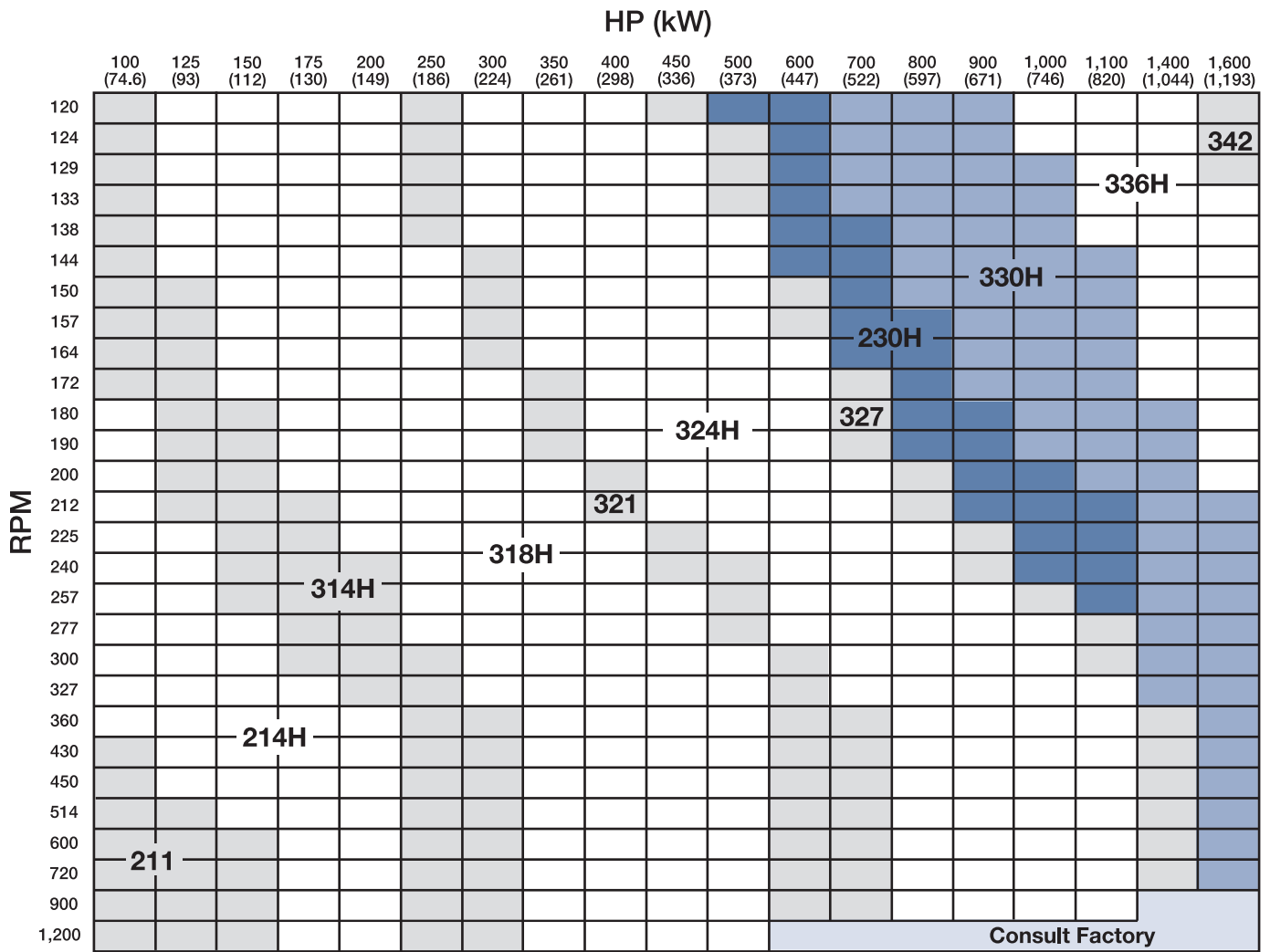

Standard Vent Clutches

Grinding Mill Quick Selection Chart

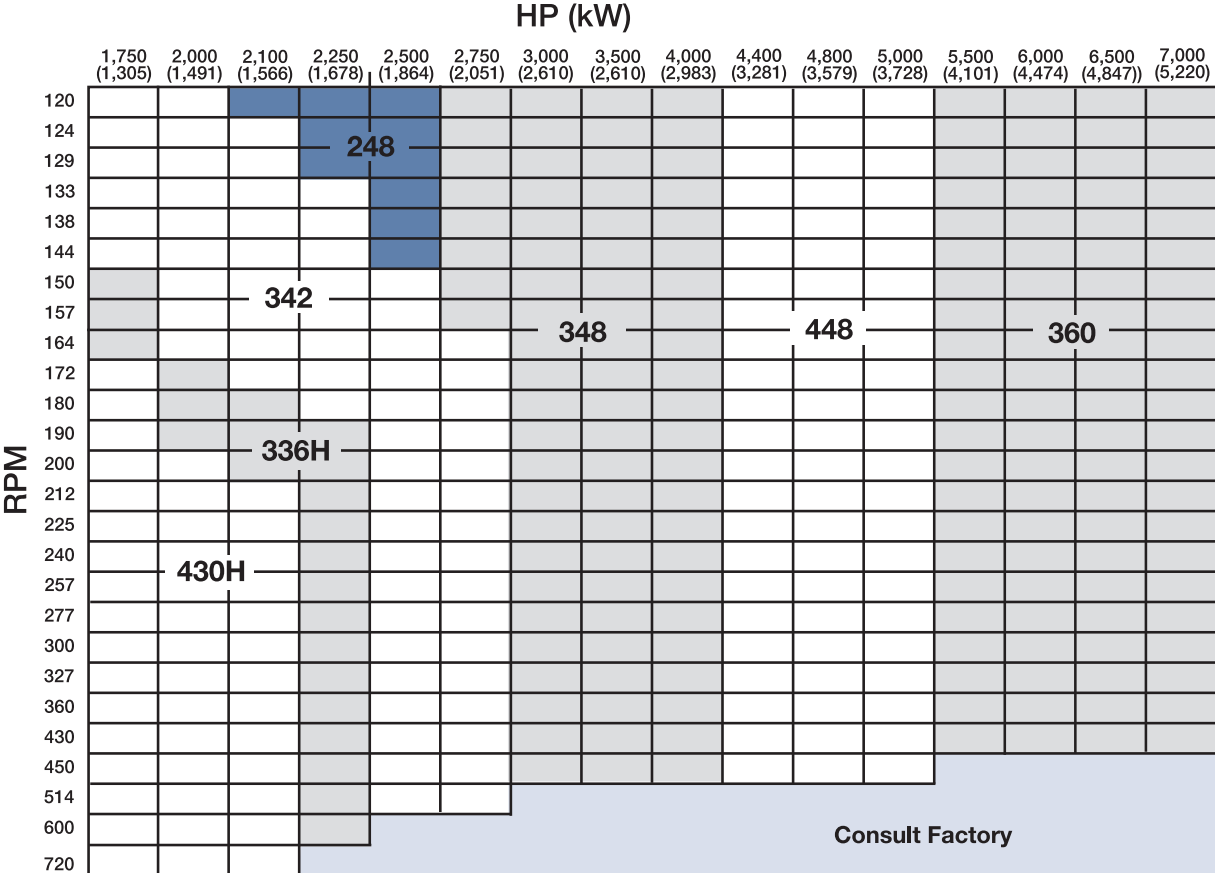
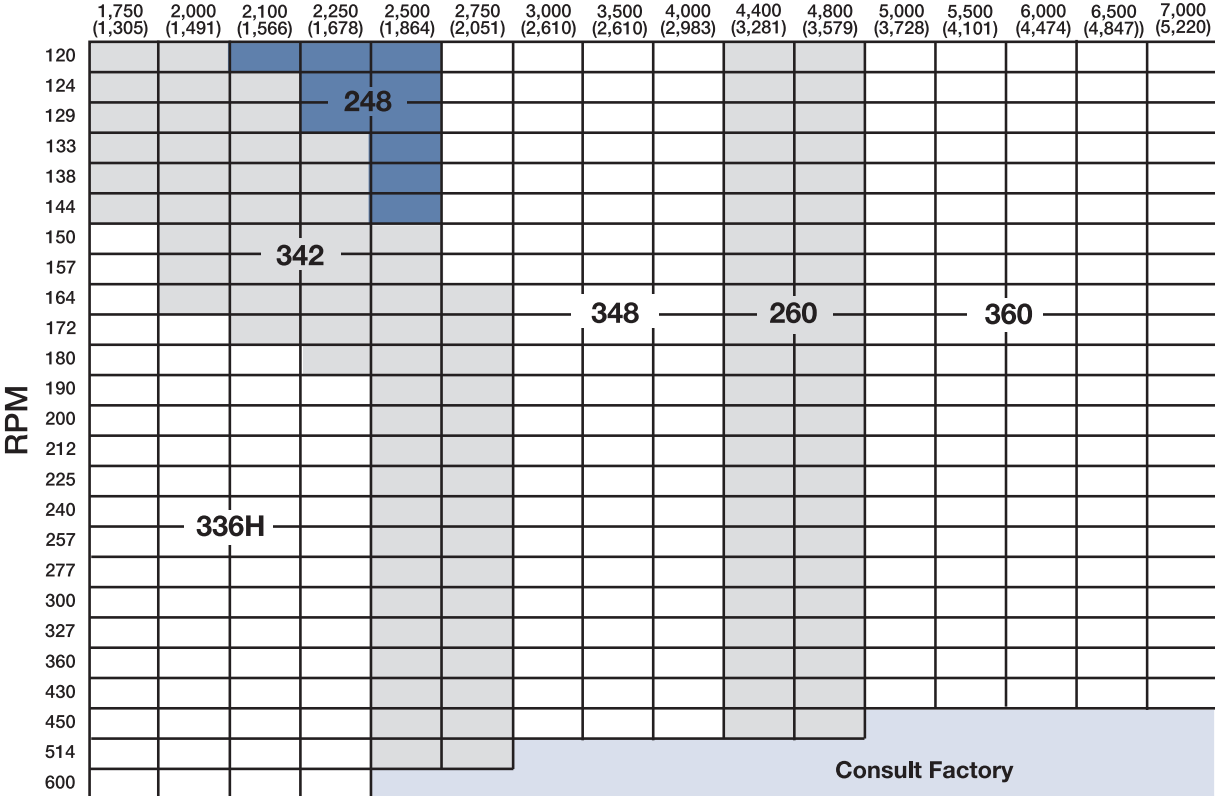

Standard Vent Clutches

Grinding Mill Quick Selection Chart

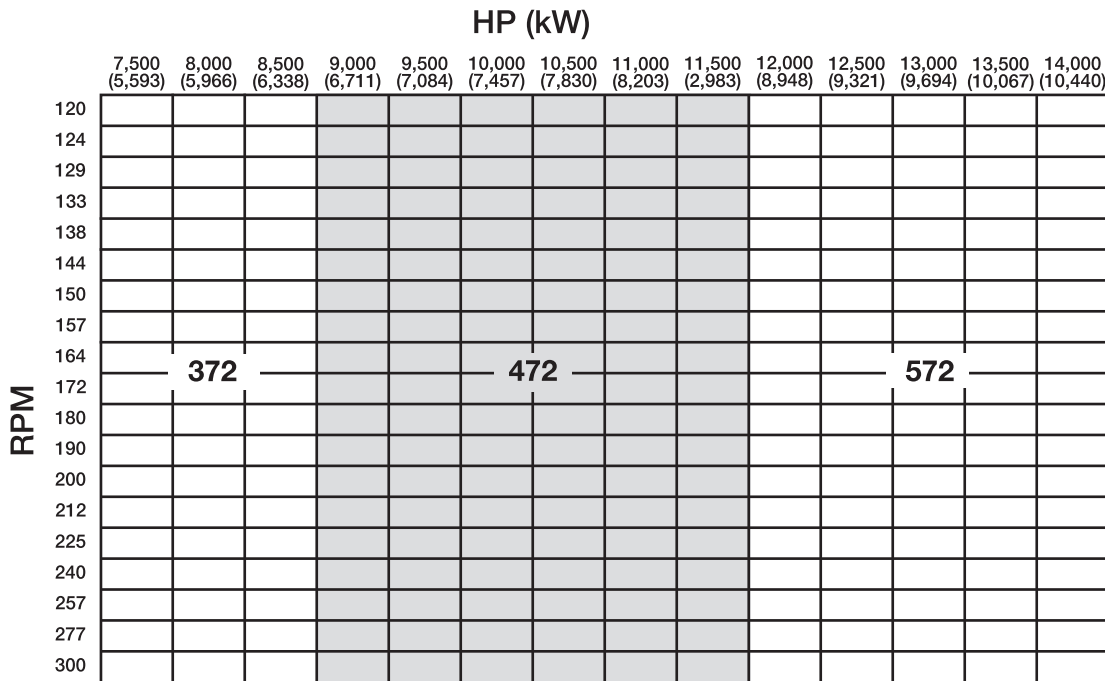
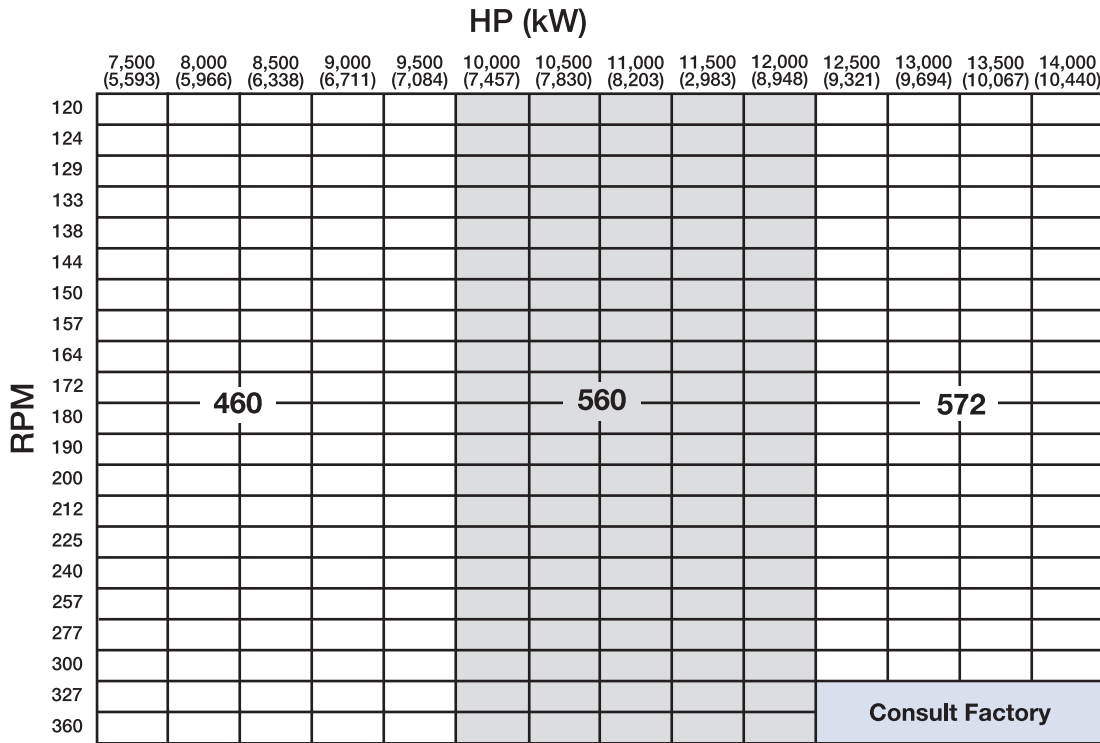

Standard Vent Clutches

Air Hose Kits

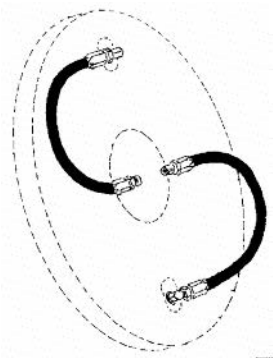

Model	Part Number
8"	8-908-812-200-3 8-908-821-200-4 QRV 8-911-813-200-3 HS
11"	8-911-812-200-4 8-911-821-200-5 QRV 8-911-813-200-3 HS
14"	8-914-812-201-5 8-914-821-202-5 QRV 8-914-813-204-3 HS

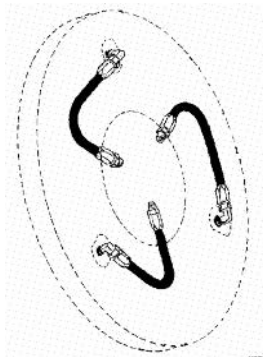

Model	Part Number
18"	8-918-812-301-5 8-918-821-300-5 QRV 8-918-815-301-3 HS
21"/18H	8-921-812-301-5 8-921-821-302-5 QRV 8-921-812-300-5 HS
24"	8-924-812-300-5 8-924-821-302-5 QRV
27"/24H	8-927-812-300-5 8-927-821-301-5 QRV 8-927-812-302-5 HS

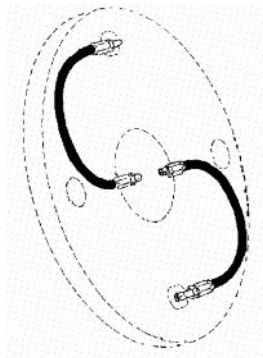

Model	Part Number
30"	8-930-815-201-5
30"H	8-931-821-200-5 QRV 8-931-812-200-5 HS
36"	8-936-815-200-5 8-936-821-200-5 QRV 8-936-815-201-5 HS
42"	8-942-815-200-5 8-942-821-200-5 QRV
48"	8-948-815-200-5 8-948-821-200-5 QRV

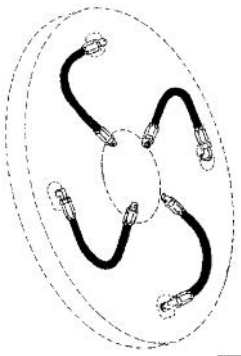

Model	Part Number
30"H	8-931-821-400-5 QRV



Model	Part Number
60"	8-960-812-300-5 8-960-834-300-5 QRV

1 Spud Hose Kits

Model	Part Number
18"	8-918-815-101-3 HS
21"	8-921-815-101-3 HS

Air hose kits contain all necessary parts (fittings, hoses and extensions) to completely plumb the clutch.

Optional Quick Release Valves can replace elbows on most units (see page 144).

Roto-couplings (see page 144).

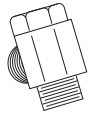

Standard Vent Clutches

Grinding Mill Clutches

Driving Adapters

The driving adapter is designed to allow the clutch to be used in a shaft-to-shaft or through-shaft coupling arrangement. The quick-change feature, using a driving elbow piece between the driving adapter and the clutch driving ring, enables replacement of any wearing clutch part without disturbing either shaft.

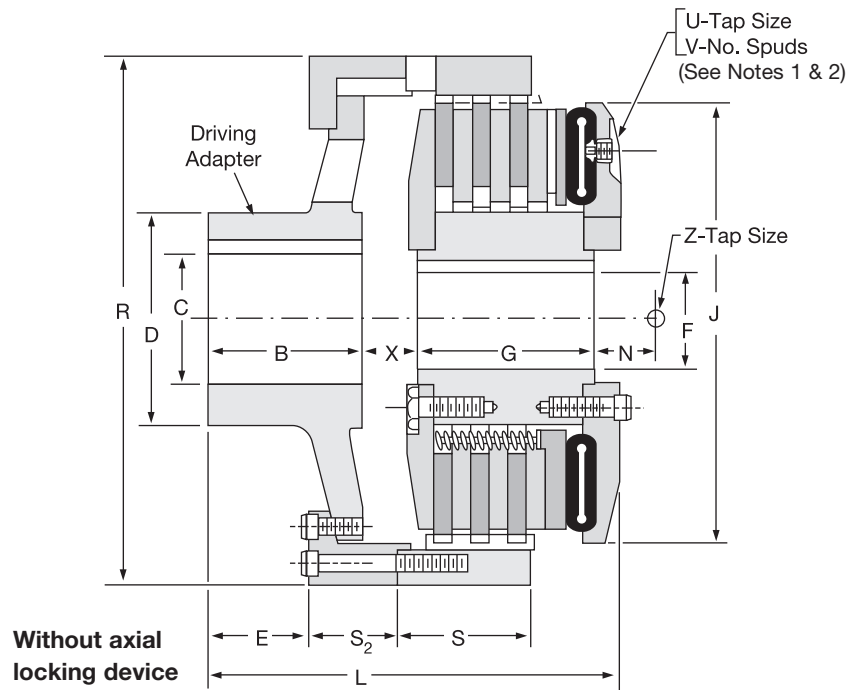

Dimensions: inches (Consult factory for drawing before final layout.)

Model Size ATD-	B	C* Max. Bore Rect. Key	C1* Max. Bore Rect. Key	D	E	F* Max. Bore Rect. Key	G	J	L	L ₁
211 GMC	3.00	3.00	—	5.00	2.00	3.00	4.25	11.94	10.00	—
214H GMC	3.25	4.13	—	6.25	2.13	3.38	5.75	16.31	11.88	—
314H GMC	3.25	4.13	—	6.25	2.13	3.38	7.18	16.31	13.38	—
318H GMC	6.00	4.00	—	6.00	4.38	4.00	7.31	21.31	17.43	—
321 GMC	6.00	6.50	—	9.00	4.00	5.38	8.63	21.31	20.50	—
324H GMC	7.31	7.50	—	10.00	5.56	5.38	8.43	27.00	21.56	—
327 GMC	7.31	7.63	—	11.50	5.56	7.00	9.00	27.00	20.94	—
230H GMC	8.75	9.38	9.38	14.00	6.50	7.00	7.88	32.38	22.63	24.43
330H GMC	8.75	9.38	9.38	14.00	6.50	7.00	10.88	32.38	25.25	26.94
336H GMC	10.00	9.38	9.38	14.00	7.88	8.00	12.88	38.25	26.75	34.75
342 GMC	10.00	12.00	12.00	18.00	7.43	10.00	11.88	44.13	27.63	34.50
248 GMC	13.63	15.00	13.25	20.00	10.13	12.00	10.88	52.38	29.63	36.88
348 GMC	13.63	15.00	13.25	20.00	10.13	12.00	13.63	52.38	32.13	39.50
260 GMC	16.25	18.00	15.00	24.00	12.25	14.00	16.25	61.50	40.00	42.50
360 GMC	16.25	18.00	15.00	24.00	12.25	14.00	20.00	61.50	43.75	46.25
460 GMC	16.25	18.00	15.00	24.00	12.25	14.00	23.50	61.50	47.13	49.63
560 GMC	20.25	17.00	17.00	30.00	16.25	17.00	27.00	61.50	—	57.20

* Maximum bore uses rectangular key, contact Wichita Engineering.

Note: For mounting, use socket head capscrews conforming to the ASTM-574-97a.

Standard Vent Clutches

Grinding Mill Clutches

With axial locking device

The axial locking device is an optional feature offered by Wichita. This device prevents damage to the mill motor bearings during motor start-up by axially locking the armature to magnetic center.

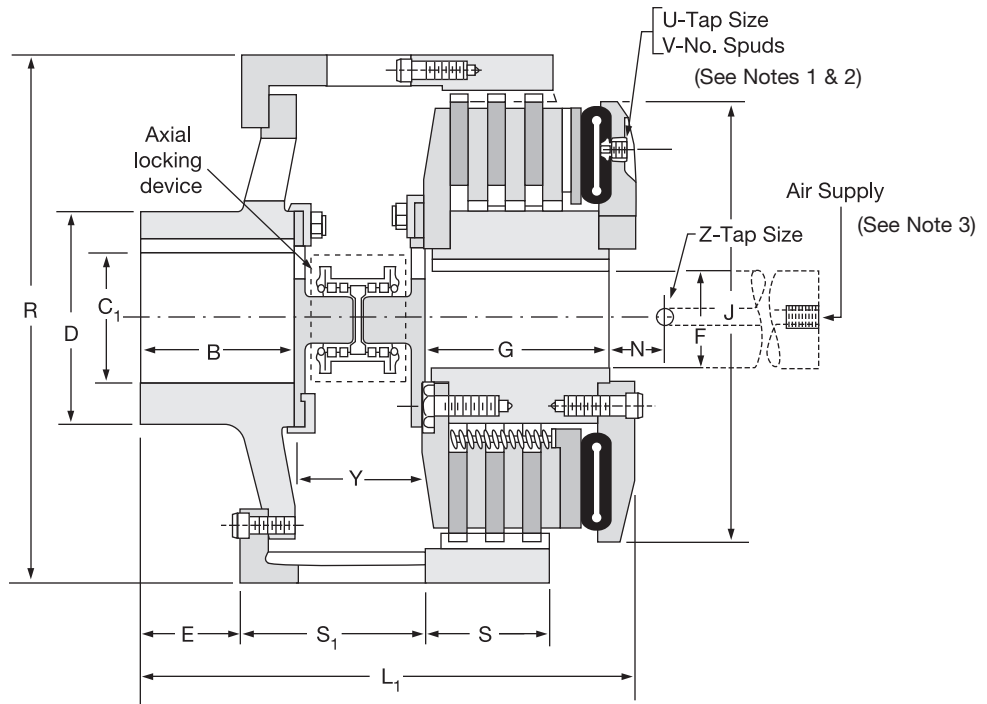

Notes:

1. Air Hose Kits, page 141.
2. Quick Release Valves, page 144.
3. Roto-couplings, page 144.

Model Size ATD-	N	R	S	S ₁	S ₂	U tap size	V spuds	X	Y	Z tap size	Air Supply
211 GMC	2.25	13.63	N/A	—	5.38	1/2" NPT	2	1.62	—	1/2" NPT	5/8"-18
214H GMC	2.25	17.50	3.25	—	3.13	1/2" NPT	2	2.13	—	1/2" NPT	5/8"-18
314H GMC	2.25	17.50	4.75	—	3.13	1/2" NPT	2	2.13	—	1/2" NPT	5/8"-18
318H GMC	2.43	22.00	5.88	—	3.50	1/2" NPT	3	3.06	—	1/2" NPT	1"-14
321 GMC	2.38	25.00	6.25	—	6.25	1/2" NPT	3	4.75	—	1/2" NPT	1"-14
324H GMC	2.75	28.00	6.25	—	5.50	1/2" NPT	3	4.50	—	1/2" NPT	1"-14
327 GMC	2.38	31.00	6.50	—	4.63	1/2" NPT	3	3.75	—	1/2" NPT	1"-14
230H GMC	2.75	34.00	5.63	5.75	5.75	1/2" NPT	4	4.25	5.00	1/2" NPT	1"-14
330H GMC	2.88	34.00	8.13	7.43	5.75	1/2" NPT	4	4.25	5.00	1/2" NPT	1"-14
336H GMC	2.88	41.00	9.13	12.13	4.00	1/2" NPT	4	2.50	10.00	1/2" NPT	1"-14
342 GMC	3.50	49.25	9.63	12.69	5.69	1/2" NPT	4	3.50	10.00	1/2" NPT	1-1/2"-12
248 GMC	3.75	56.00	7.38	13.25	6.13	1/2" NPT	4	2.75	10.00	1/2" NPT	1-1/2"-12
348 GMC	3.50	56.00	9.88	13.38	6.13	1/2" NPT	4	2.75	10.00	1/2" NPT	1-1/2"-12
260 GMC	2.00	66.75	9.00	14.00	11.50	1/2" NPT	6	7.50	10.00	1/2" NPT	1-1/2"-12
360 GMC	2.00	66.75	13.00	14.00	11.50	1/2" NPT	6	7.50	10.00	1/2" NPT	1-1/2"-12
460 GMC	2.00	66.75	16.50	14.00	11.50	1/2" NPT	6	7.50	10.00	1/2" NPT	1-1/2"-12
560 GMC	4.0	74.25	20.13	14.60	—	1/2" NPT	6	—	10.00	1/2" NPT	1-1/2"-12

Standard Vent Clutches

Grinding Mill Clutches

Quick Release Valve

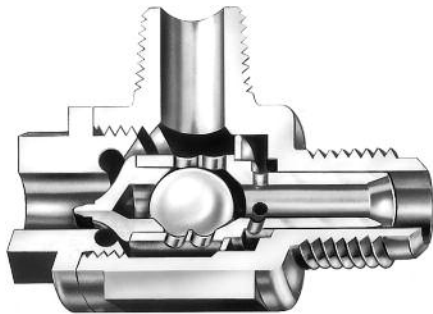

8-263-610-011-1 7/8" - 14 Thread
8-263-610-021-1 1/2" NPT

The Wichita Springless Quick Release Valve discharges twice as fast as any other valve tested in our laboratory and is four to five times faster than some common makes of valves.

This valve will close and seal with less than 20 lbs. pressure. Most others require 25 to 30 lbs. to definitely seal. In actual tests, the Wichita Valve made many hundreds of thousands of engagements and disengagements before the slightest leak occurred, or any parts needed replacement. Other valves which were tested required major replacement in fewer than 20,000 cycles.

Quality Material

- Body and Cap: High strength aluminum alloy
- Stem: Molded nylon
- Check Valve: Nylon ball
- "O" Ring: Neoprene

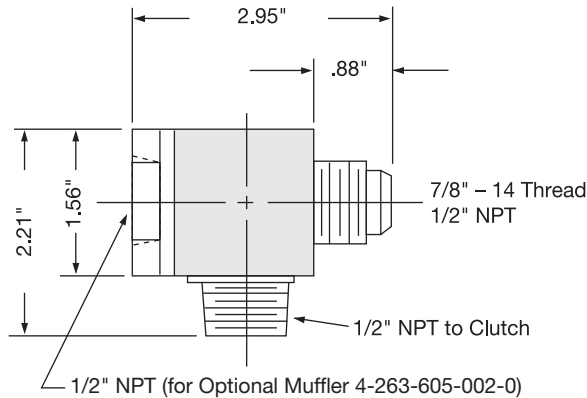

Standard thread arrangement of 1/2" size. 1/2" pipe thread on the tube connection and choice of 1/2" pipe thread, or standard 7/8-14NF thread for flared fitting thread on inlet connection. (Fits standard No. 10 high-pressure hose fitting.)

Roto-Couplings

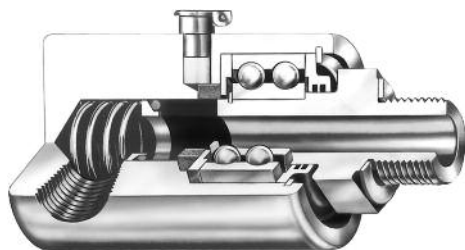

The Wichita Roto-coupling is a device to connect, or couple, a non-rotating air, gas, or fluid line to a rotating shaft.

- Long life, no maintenance
- Felt seal eliminates bearing contamination
- Fast, easy installation

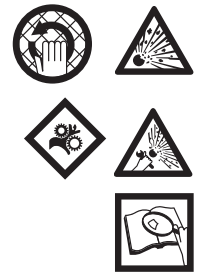
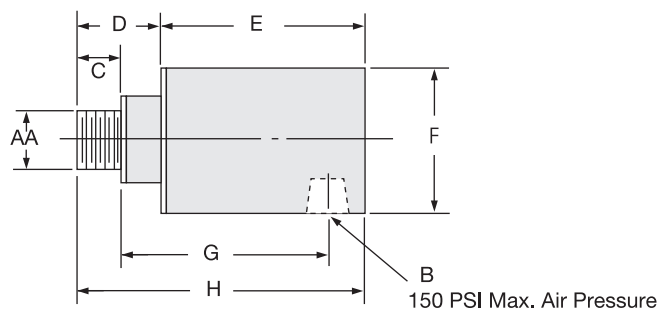

Dimensions: inches

Wichita Part No.	AA	B	C	D	E	F	G	H	Max. RPM
8-240-701-003-1	5/8-18NF	1/4" NPT	.40	1.046	2.250	1.500	2.13	3.297	3,500
8-240-705-001-1	1"-14 NF	1/2" NPT	.75	1.250	3.188	2.500	3.00	4.438	3,500
8-240-708-001-1	1"-14 NF	3/4" NPT	.75	1.313	4.688	2.875	3.69	5.440	3,500
8-240-710-002-1	1-1/2"-12 NF	1" NPT	1.13	1.937	4.875	3.250	3.44	6.812	2,500
8-240-712-001-1	2"-12 NF	1-1/2" NPT	1.13	2.813	5.250	4.250	5.38	8.062	2,500
8-240-714-001-3	2" NPT	2" NPT	1.50	3.000	7.062	4.625	7.00	10.062	1,000
8-240-716-000-3	2-1/2" NPT	2-1/2" NPT	1.88	3.250	9.375	7.000	7.75	12.625	750